

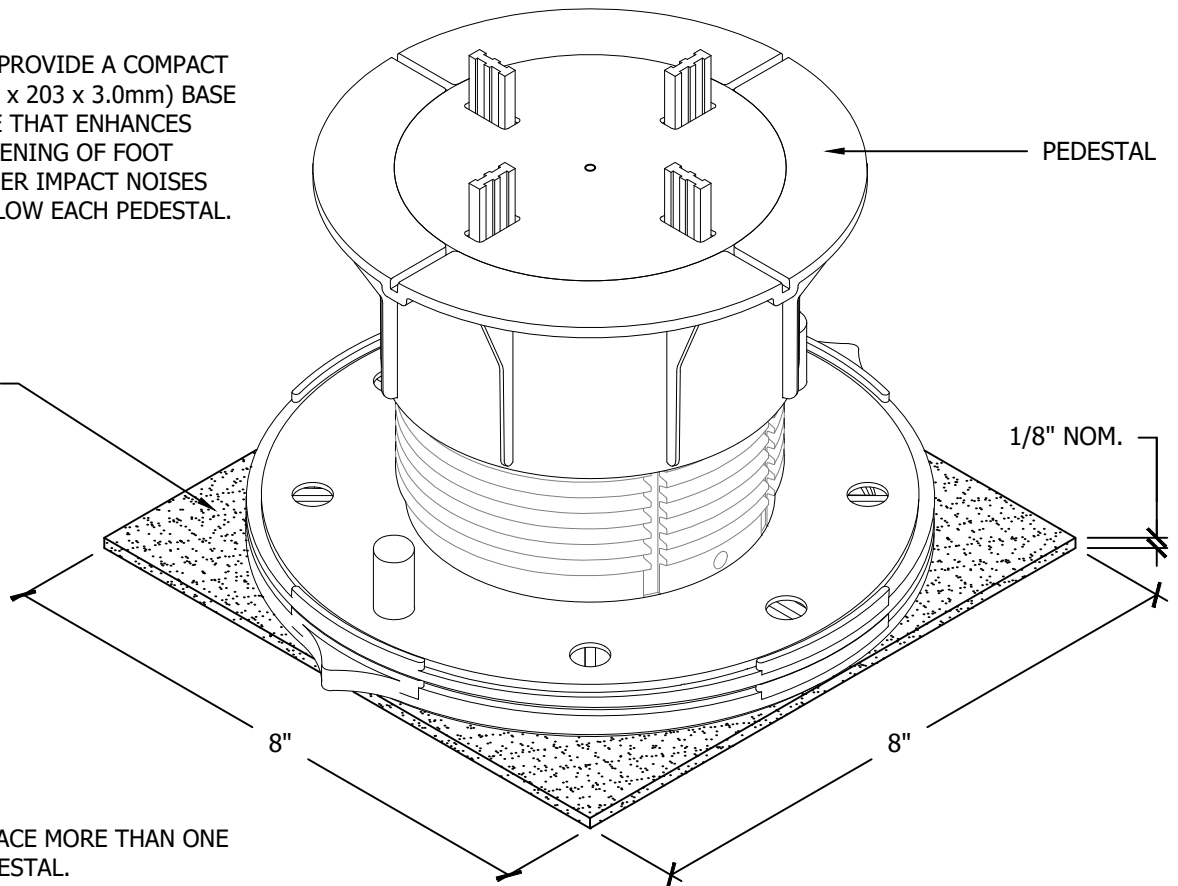

701 Osage Street, Unit 120, Denver, CO 80204 USA  
 Phone 303.892.0400 Toll Free 800.333.4234 Fax 303.825.5988  
 EMail [info@bisonip.com](mailto:info@bisonip.com) Web [www.bisonip.com](http://www.bisonip.com)

SP8 SOUND PADS PROVIDE A COMPACT 8" x 8" x 1/8" (203 x 203 x 3.0mm) BASE BEARING SURFACE THAT ENHANCES THE SOUND DAMPENING OF FOOT TRAFFIC AND OTHER IMPACT NOISES WHEN PLACED BELOW EACH PEDESTAL.

SP8 SOUND PAD



NOTE: DO NOT PLACE MORE THAN ONE SP8 BELOW A PEDESTAL.

SYSTEM	ASTM E492	ASTM E90
	IIC	STC
6" CONCRETE SLAB	30	54
6" CONCRETE SLAB, BISON SP8 SOUND PAD, BISON PEDESTALS, BISON 2CM & PAVER TRAY	61	59
6" CONCRETE SLAB, BISON SP8 SOUND PAD, BISON PEDESTALS, BISON WOOD TILES	57	54

\*FIGURES SHOWN ABOVE ARE FOR ESTIMATING PURPOSES ONLY. ACTUAL SOUND REDUCTION WILL VARY WITH PROJECT CONDITIONS AND SHOULD BE TESTED IN A SMALL AREA ON SITE TO VERIFY PERFORMANCE BEFORE AN ORDER IS PLACED. CHECK ROOFING MATERIAL COMPATIBILITY WITH SUBSTRATE MANUFACTURER. SEE SPECIFICATIONS FOR MORE INFORMATION.

**GENERAL NOTES: APPLY TO ALL OF THE ABOVE PRODUCTS**

1. INSTALLATION MUST BE COMPLETED IN ACCORDANCE WITH BISON INNOVATIVE PRODUCTS SPECIFICATIONS.
2. DRAWINGS NOT TO SCALE.
3. CONTRACTOR'S NOTE: FOR PRODUCT AND COMPANY INFORMATION VISIT [www.BisonIP.com](http://www.BisonIP.com)

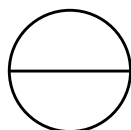

**SP8 SOUND PAD**

SP8 INSTALLATION FOR IMPACT NOISE REDUCTION